

NEW

PFHE

## The planetary gearbox with flange output shaft for high-load applications

The **PFHE** represents an economically attractive alternative for high-load applications in which high radial loads occur. The combination of special pre-stressed inclined roller bearings and a flanged output shaft in accordance with EN ISO 9409-1 gives the **PFHE** a very high load capacity. Thanks to the radial shaft seal that is used, this gearbox achieves protection class IP65 at the output side and can therefore also withstand adverse usage conditions.

Nominal output torque **15 - 260 Nm**

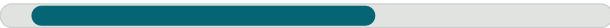

Torsional backlash **7 - 12 arcmin**



Tilting moment **110 - 407 Nm**

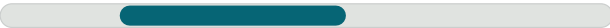

Protection class **IP65**



Frame sizes

64

90

110

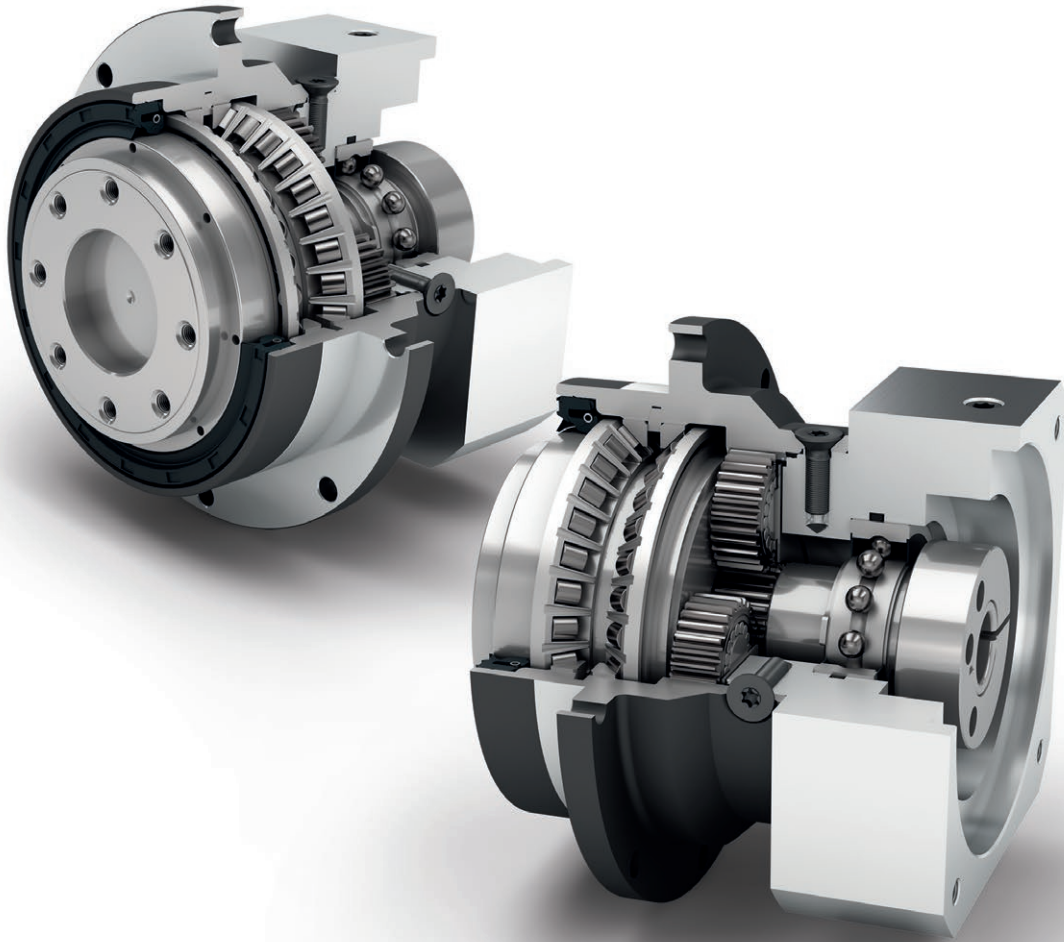

Economy Line

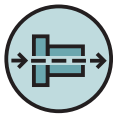

Coaxial gearbox



Spur gear



Preloaded angular contact roller bearings



Flange output shaft (ISO 9409)



Equidirectional rotation

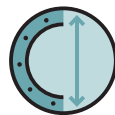

Extra large round type output flange



Rotary shaft seal



Planet carrier in disc design

Code	Gearbox characteristics			PFHE064	PFHE090	PFHE110	p <sup>(1)</sup>
	Service life (L <sub>10h</sub> )	t <sub>L</sub>	h	30,000			
	Efficiency at full load <sup>(2)</sup>	η	%	97			
	Min. operating temperature	T <sub>min</sub>	°C	-25 (-13)			
	Max. operating temperature	T <sub>max</sub>	(°F)	90 (194)			
	Protection class			IP65			
<b>S</b>	Standard lubrication			Grease (lifetime lubrication)			
<b>F</b>	Food grade lubrication			Grease (lifetime lubrication)			
<b>L</b>	Low temperature lubrication <sup>(3)</sup>			Grease (lifetime lubrication)			
	Installation position			Any			
<b>S</b>	Standard backlash	j <sub>t</sub>	arcmin	< 10	< 7	< 7	1
				< 12	< 9	< 9	2
	Torsional stiffness <sup>(2)</sup>	c <sub>g</sub>	Nm/arcmin (lb <sub>f</sub> .in/ arcmin)	5.4 - 10.6 (48 - 94)	16.1 - 32.5 (142 - 288)	37.0 - 77.0 (327 - 682)	1
				5.0 - 11.5 (44 - 102)	15.7 - 38.5 (139 - 341)	30.0 - 95.0 (266 - 841)	2
	Gearbox weight	m <sub>G</sub>	kg (lb <sub>m</sub> )	1.1 (2.4)	3.3 (7.3)	7.1 (15.7)	1
				1.5 (3.3)	3.7 (8.2)	9.1 (20.1)	2
<b>S</b>	Standard surface			Housing: Steel – heat-treated and post-oxidized (black)			
	Running noise <sup>(4)</sup>	Q <sub>g</sub>	dB(A)	60	62	65	
	Max. bending moment based on the gearbox input flange <sup>(5)</sup>	M <sub>b</sub>	Nm (lb <sub>f</sub> .in)	8 (71)	16 (142)	40 (354)	

Output shaft loads			PFHE064	PFHE090	PFHE110	p <sup>(1)</sup>
Radial force for 20,000 h <sup>(6)(7)</sup>	F <sub>r 20.000 h</sub>	N (lb <sub>f</sub> )	2300 (517)	4100 (922)	5150 (1158)	
Axial force for 20,000 h <sup>(6)(7)</sup>	F <sub>a 20.000 h</sub>		2850 (641)	5450 (1225)	6450 (1450)	
Radial force for 30,000 h <sup>(6)(7)</sup>	F <sub>r 30.000 h</sub>		2000 (450)	3650 (821)	4550 (1023)	
Axial force for 30,000 h <sup>(6)(7)</sup>	F <sub>a 30.000 h</sub>		2500 (562)	4800 (1079)	5600 (1259)	
Maximum radial force <sup>(7)(8)</sup>	F <sub>r Stat</sub>		2300 (517)	4100 (922)	5150 (1158)	
Maximum axial force <sup>(7)(8)</sup>	F <sub>a Stat</sub>		2850 (641)	5450 (1225)	6450 (1450)	
Tilting moment for 20,000 h <sup>(6)(8)</sup>	M <sub>K 20.000 h</sub>	Nm (lb <sub>f</sub> .in)	110 (974)	278 (2461)	407 (3602)	
Tilting moment for 30,000 h <sup>(6)(8)</sup>	M <sub>K 30.000 h</sub>		96 (850)	248 (2195)	360 (3186)	

Moment of inertia			PFHE064	PFHE090	PFHE110	p <sup>(1)</sup>
Mass moment of inertia <sup>(2)</sup>	J	kgcm <sup>2</sup> (lb <sub>f</sub> .in.s <sup>2</sup> 10 <sup>-4</sup> )	0.073 - 0.224 (0.646 - 1.983)	0.407 - 1.170 (3.602 - 10.355)	1.505 - 3.658 (13.320 - 32.376)	1
			0.064 - 0.132 (0.566 - 1.168)	0.356 - 0.667 (3.151 - 5.903)	1.377 - 2.432 (12.187 - 21.525)	2

(1) Number of stages  
(2) The ratio-dependent values can be retrieved in Tec Data Finder – www.neugart.com  
(3) T<sub>min</sub> = -40°C. Optimal operating temperature max. 50°C  
(4) Sound pressure level from 1 m, measured on input running at n<sub>1</sub>=3000 rpm no load; i=5  
(5) Max. motor weight\* in kg = 0.2 x M<sub>b</sub> / motor length in m  
\* with symmetrically distributed motor weight  
\* with horizontal and stationary mounting  
(6) These values are based on an output shaft speed of n<sub>2</sub>=100 rpm  
(7) Based on the end of the output shaft  
(8) Other (sometimes higher) values following changes to T<sub>2N</sub>, F<sub>r</sub>, F<sub>a</sub>, cycle, and service life of bearing. Application specific configuration with NCP – www.neugart.com

Output torques			PFHE064	PFHE090	PFHE110	i <sup>(1)</sup>	p <sup>(2)</sup>
Nominal output torque <sup>(3)</sup>	T <sub>2N</sub>	Nm (lb <sub>r</sub> .in)	28 (248)	85 (752)	115 (1018)	3	1
			38 (336)	115 (1018)	155 (1372)	4	
			40 (354)	110 (974)	195 (1726)	5	
			25 (221)	65 (575)	135 (1195)	7	
			18 (159)	50 (443)	120 (1062)	8	
			15 (133)	38 (336)	95 (841)	10	
			44 (389)	130 (1151)	240 (2124)	9	2
			44 (389)	120 (1062)	260 (2301)	12	
			44 (389)	110 (974)	230 (2036)	15	
			44 (389)	120 (1062)	260 (2301)	16	
			44 (389)	120 (1062)	260 (2301)	20	
			40 (354)	110 (974)	230 (2036)	25	
			44 (389)	120 (1062)	260 (2301)	32	
			40 (354)	110 (974)	230 (2036)	40	
			18 (159)	50 (443)	120 (1062)	64	
			15 (133)	38 (336)	95 (841)	100	
Max. output torque <sup>(4)</sup>	T <sub>2max</sub>	Nm (lb <sub>r</sub> .in)	45 (398)	136 (1204)	184 (1629)	3	1
			61 (540)	184 (1629)	248 (2195)	4	
			64 (566)	176 (1558)	312 (2761)	5	
			40 (354)	104 (920)	216 (1912)	7	
			29 (257)	80 (708)	192 (1699)	8	
			24 (212)	61 (540)	152 (1345)	10	
			70 (620)	208 (1841)	384 (3399)	9	2
			70 (620)	192 (1699)	416 (3682)	12	
			70 (620)	176 (1558)	368 (3257)	15	
			70 (620)	192 (1699)	416 (3682)	16	
			70 (620)	192 (1699)	416 (3682)	20	
			64 (566)	176 (1558)	368 (3257)	25	
			70 (620)	192 (1699)	416 (3682)	32	
			64 (566)	176 (1558)	368 (3257)	40	
			29 (257)	80 (708)	192 (1699)	64	
			24 (212)	61 (540)	152 (1345)	100	

PFHE

<sup>(1)</sup> Ratios (i=n<sub>1</sub>/n<sub>2</sub>)  
<sup>(2)</sup> Number of stages  
<sup>(3)</sup> Application specific configuration with NCP – [www.neugart.com](http://www.neugart.com)  
<sup>(4)</sup> 30,000 rotations of the output shaft permitted; see page 142

Output torques			PFHE064	PFHE090	PFHE110	$i^{(1)}$	$p^{(2)}$
Emergency stop torque <sup>(3)</sup>	$T_{2Stop}$	Nm (lb <sub>f</sub> .in)	66 (584)	180 (1593)	390 (3452)	3	1
			88 (779)	240 (2124)	520 (4602)	4	
			80 (708)	220 (1947)	500 (4425)	5	
			80 (708)	178 (1575)	340 (3009)	7	
			80 (708)	190 (1682)	380 (3363)	8	
			80 (708)	200 (1770)	480 (4248)	10	
			88 (779)	260 (2301)	500 (4425)	9	2
			88 (779)	240 (2124)	520 (4602)	12	
			88 (779)	220 (1947)	500 (4425)	15	
			88 (779)	240 (2124)	520 (4602)	16	
			88 (779)	240 (2124)	520 (4602)	20	
			80 (708)	220 (1947)	500 (4425)	25	
			88 (779)	240 (2124)	520 (4602)	32	
			80 (708)	220 (1947)	500 (4425)	40	
			80 (708)	190 (1682)	380 (3363)	64	
			80 (708)	200 (1770)	480 (4248)	100	

Input speeds			PFHE064	PFHE090	PFHE110	$i^{(1)}$	$p^{(2)}$
Average thermal input speed at $T_{2N}$ and S1 <sup>(4)(5)</sup>	$n_{1N}$	rpm	2350 <sup>(6)</sup>	1900 <sup>(6)</sup>	1600 <sup>(6)</sup>	3	1
			2950 <sup>(6)</sup>	2200 <sup>(6)</sup>	1900 <sup>(6)</sup>	4	
			3550 <sup>(6)</sup>	2750 <sup>(6)</sup>	2200 <sup>(6)</sup>	5	
			4500	4000 <sup>(6)</sup>	3350 <sup>(6)</sup>	7	
			4500	4000	3500 <sup>(6)</sup>	8	
			4500	4000	3500	10	
			4500	4000 <sup>(6)</sup>	3300 <sup>(6)</sup>	9	2
			4500	4000	3500 <sup>(6)</sup>	12	
			4500	4000	3500	15	
			4500	4000	3500	16	
			4500	4000	3500	20	
			4500	4000	3500	25	
			4500	4000	3500	32	
			4500	4000	3500	40	
			4500	4000	3500	64	
			4500	4000	3500	100	
			Max. mechanical input speed <sup>(4)</sup>	$n_{1Limit}$	rpm	7500	

<sup>(1)</sup> Ratios ( $i=n_1/n_2$ )

<sup>(2)</sup> Number of stages

<sup>(3)</sup> Permitted 1000 times

<sup>(4)</sup> Application-specific speed configurations with NCP – [www.neugart.com](http://www.neugart.com)

<sup>(5)</sup> See page 142 for the definition

<sup>(6)</sup> Average thermal input speed at 50%  $T_{2N}$  and S1

PFHE064  
PFHE090

PFHE110

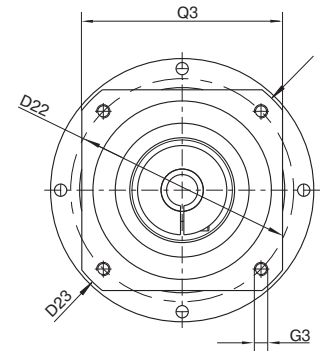
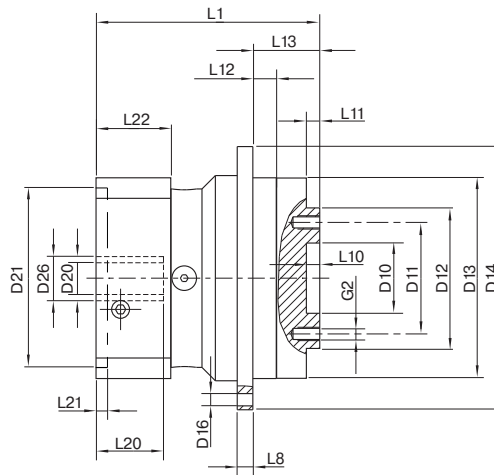
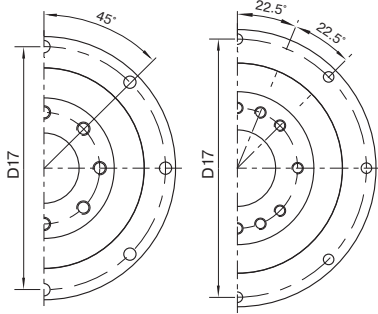

Drawing corresponds to a PFHE090 / 1-stage / flange output shaft / 19 mm clamping system / motor adaptation – one part / B5 flange type motor

All other variants can be retrieved in the Tec Data Finder at [www.neugart.com](http://www.neugart.com)

Geometry <sup>(1)</sup>			PFHE064	PFHE090	PFHE110	p <sup>(2)</sup>	Code					
Centering Ø output shaft	D10	H7	20 (0.787)	31.5 (1.240)	40 (1.575)							
Pitch circle Ø output shaft	D11		31.5 (1.240)	50 (1.969)	63 (2.480)							
Centering Ø output shaft	D12	h7	40 (1.575)	63 (2.480)	80 (3.150)							
Centering Ø output flange	D13		64 (2.520)	90 (3.543)	110 (4.331)							
Flange Ø output	D14		86 (3.386)	118 (4.646)	145 (5.709)							
Mounting bore output	D16		4.5 8x45°	5.5 8x45°	5.5 8x45°							
Pitch circle Ø output flange	D17		79 (3.110)	109 (4.291)	135 (5.315)							
Min. total length	L1		72 (2.835)	100.5 (3.957)	117 (4.606)	1						
			84.5 (3.327)	118 (4.646)	144 (5.669)	2						
Flange thickness output	L8		4 (0.157)	7 (0.276)	8 (0.315)							
Centering depth output shaft	L10		4 (0.157)	6 (0.236)	6 (0.236)							
	L11		3 (0.118)	6 (0.236)	7 (0.256)							
Centering depth output flange	L12		7.5 (0.295)	10.5 (0.413)	10.5 (0.413)							
Output flange length	L13		19.5 (0.768)	30 (1.181)	29 (1.142)							
Clamping system diameter input	D26	More information on page 131										
Motor shaft diameter j6/k6	D20	The dimensions vary with the motor/gearbox flange. The input flange dimensions can be retrieved for each specific motor in Tec Data Finder at <a href="http://www.neugart.com">www.neugart.com</a>										
Max. permis. motor shaft length	L20											
Min. permis. motor shaft length												
Centering Ø input	D21											
Centering depth input	L21											
Pitch circle Ø input	D22											
Motor flange length	L22											
Diagonal dimension input	D23											
Mounting thread x depth	G3						4x					
Flange cross section input	Q3						■					
Flange output shaft (similar EN ISO 9409-1)												<b>D</b>
Number x thread x depth	G2							8 x M5x7	8 x M6x10	12 x M6x12		

<sup>(1)</sup> Dimensions in mm

<sup>(2)</sup> Number of stages